



ARROW LUX

TAMPER-EVIDENT TIGHTENING SEAL

Description:

- Made of propylene
- Operation temperature: -50°C / +120°C
- Collet of unique design made of stainless, spring steel
- Company logo and 8-digit sequential numbering
- Laser marking through the thickness of the material
- Additional technological holes for the seal tail
- The cap glows under UV light
- Operating length of the seal: 385 mm (15.16")



Color options:

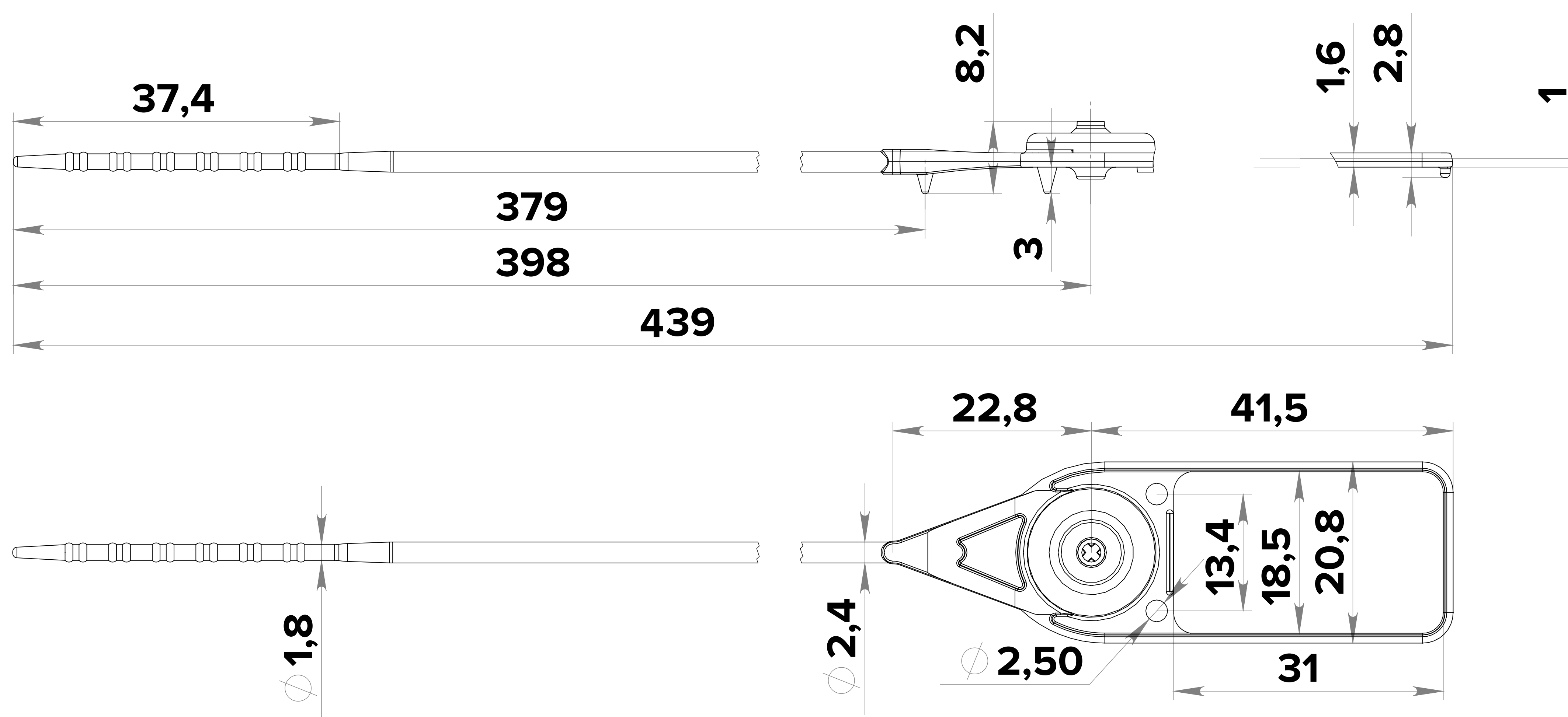

Package:	Size:	Quantity:	Weigh:
Package	-	100 pcs.	-
Corrugated box	450×330×220mm (17.72×12.99×8.66")	0100-1,000 pcs.	0-3.7 kg (0-8.16 lbs.)
Corrugated box	460×360×330mm (18.11×14.17×12.99")	1,000-2,000 pcs.	3.7-7.2 kg (8.16-15.87 lbs.)