



## TURBION

### TAMPER-EVIDENT ROTOR SEAL

#### Description:

- Made of polycarbonate
- Operation temperature: -50°C / +120°C
- Company logo and 8-digit sequential numbering
- Laser marking through the thickness of the material
- Ratchet mechanism with 4-blade rotor
- Glowing under UV rays
- Dimension specifications: 31.5x30x32.8 mm (1.24x1.18x1.29")
- Diameter of holes: 1.2 mm (0.047")

#### Color options:

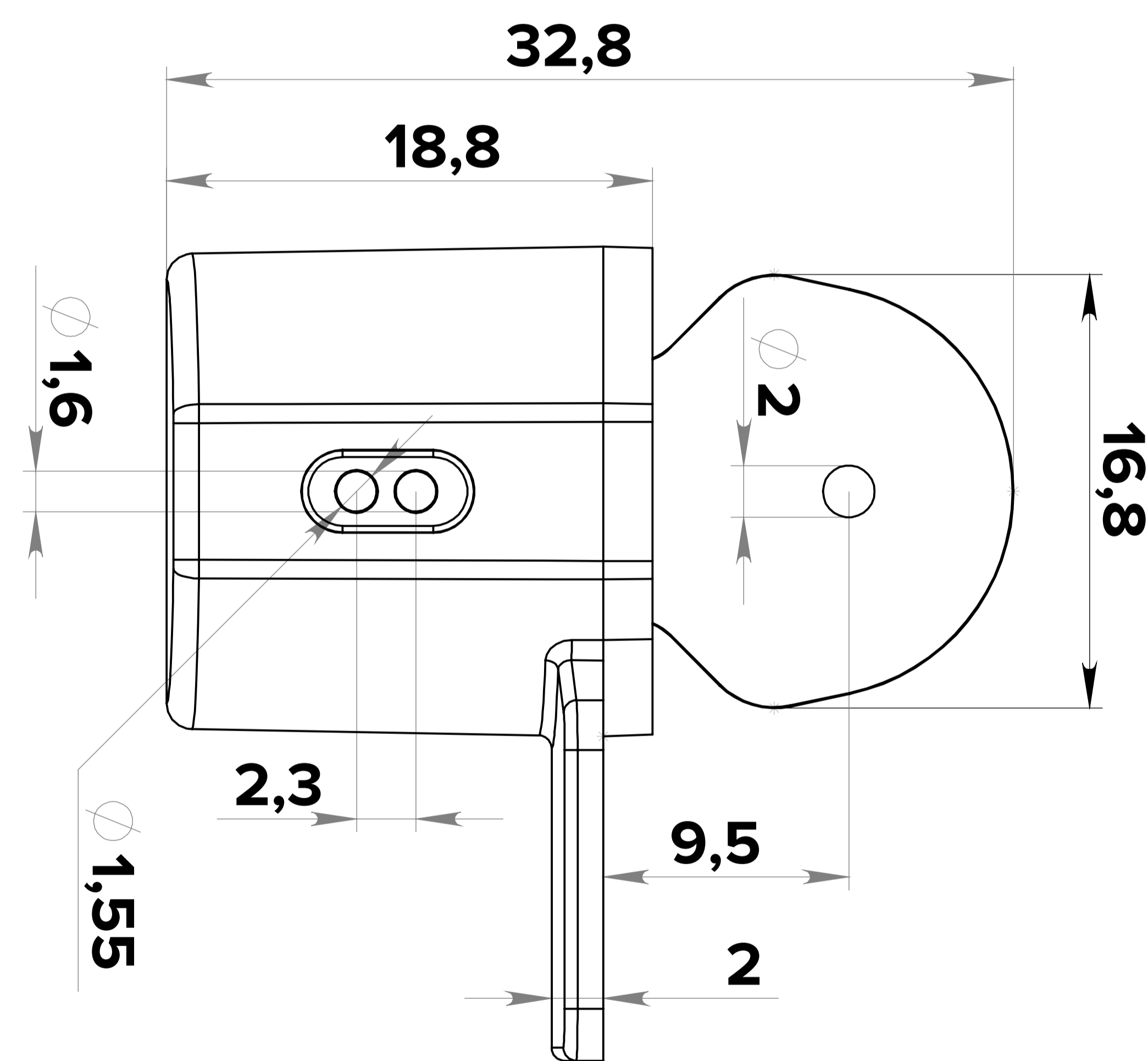
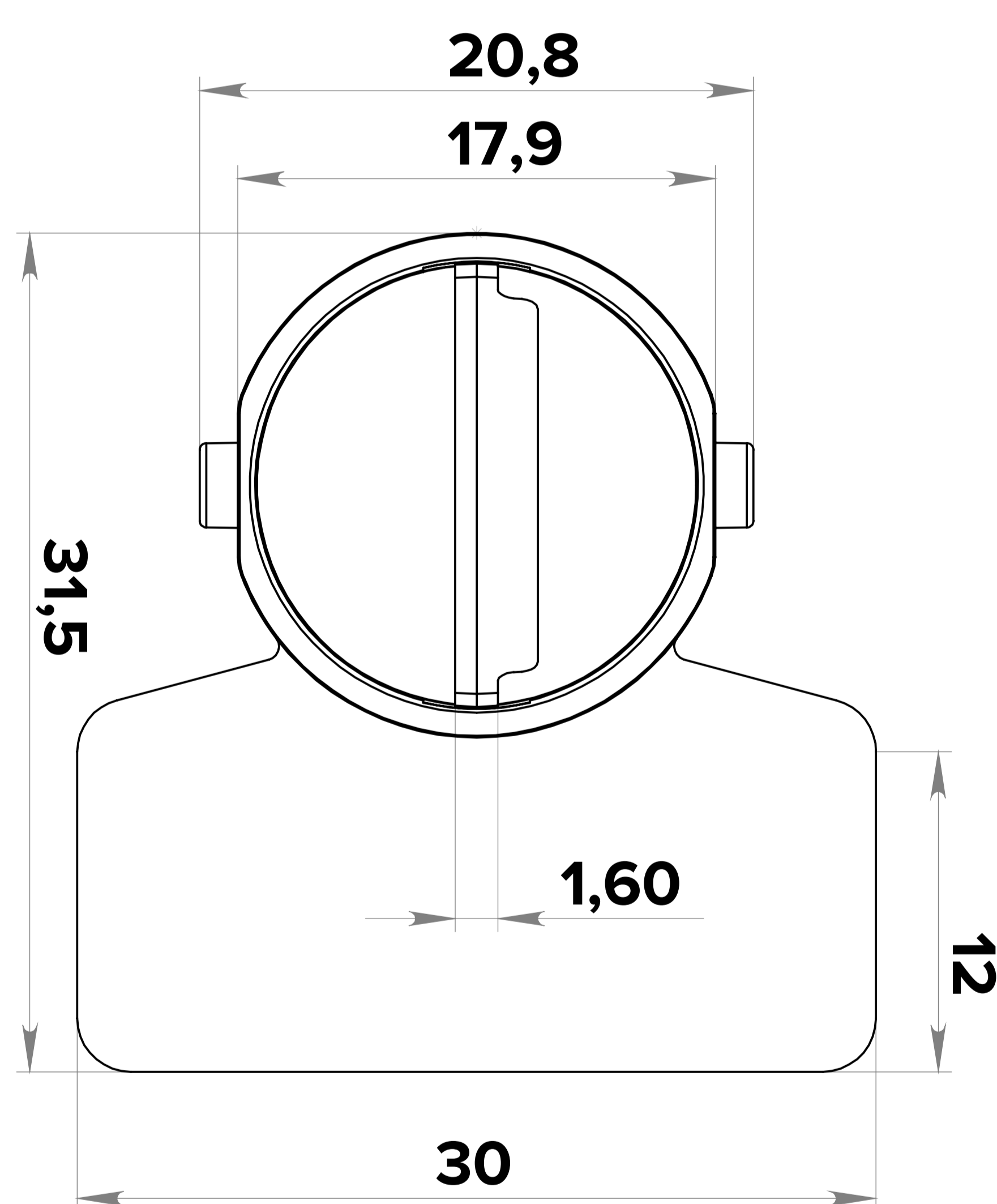
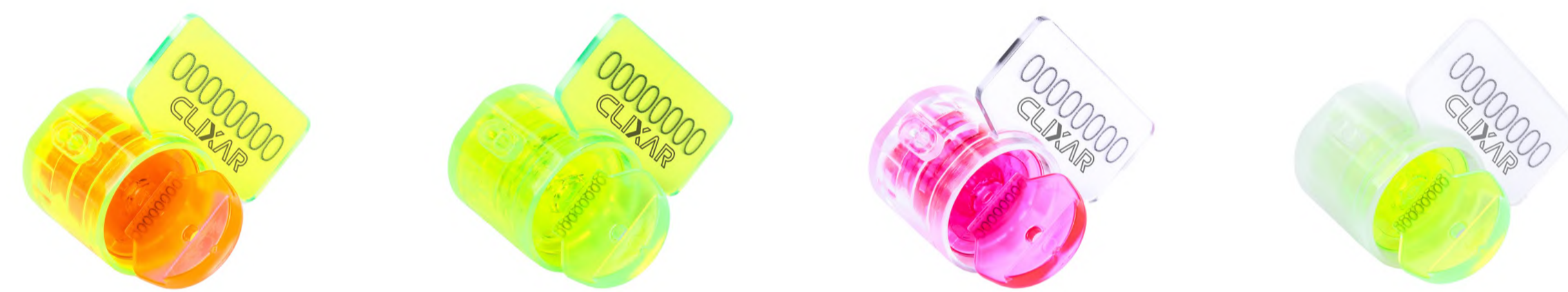

Package:	Size:	Quantity:	Weigh:
Package of	-	50 pcs.	-
Box	310×210×140mm (12.21x8.27x5.51")	0050-500 pcs.	0-2,8 kg (0-6.17 lbs.)
Box	380×285×335mm (15x11.2x13.2")	500-1,500 pcs.	2.8-9.8 kg (6.17-21.6 lbs.)
Box	Box: 460×360×330mm (18.11x14.17x12.99")	1,500-2,500 pcs.	9.8-14.6 kg (21.6-32.19 lbs.)